

PFAFF

fine sewing

5483

Ultra-high-speed chainstitch seamer
with drop feed



PFAFF 5483

Special features:

- Usable in all branches of the sewing industry.
- Maximum sewing speed: 6,000 s.p.m.
- Optimum sewing reliability, even at maximum speed.
- Very good feed characteristics at low foot pressure.
- Low-noise, low-vibration running, even at top speed.
- Conveniently arranged controls.
- Infinitely variable stitch length.
- Easy maintenance, due to:
 - centralized fresh-oil lubrication of needle bar and hook drive
 - maintenance-free anti-friction bearings
 - enclosed gearcase with long-life pad lubrication
 - built-in adjustment gauges for quick and reliable adjustment
- High sewing output and simple operation, due to time- and cost-saving work aids, such as:
 - thread trimmer,
 - automatic foot lift,
 - backtacking system,
 - needle positioning system, etc.
- Standardized parts within the 5480 Series, thus lower costs in store-keeping.

Stitch type:

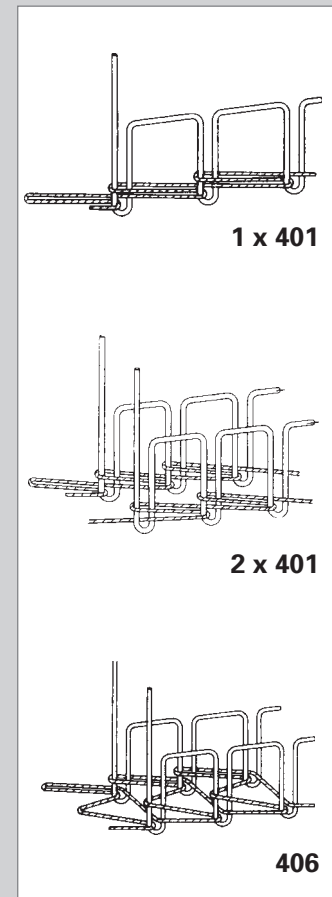

- H** = Needle bar stroke 33 mm
B = For sewing medium materials,
 needle size (Nm) in $\frac{1}{100}$ mm: 80 to 100
S = Machine version for sewing fabrics

Standard sales range:

	Thread trimmer -900/71	Foot lift -910/04	Foot lift and puller lift -910/24	Stitch condensation -917/35	Backtacking system -911/35	Stitch type	Needle gauge in mm	Air filter/regulator -925/03	Max. speed, r.p.m. depending on material and operation	Needle system	Max. stitch length
Single-needle versions											
5483-814/01-6/01 BS						401			6000	4463-35	4.5
5483-814/01-6/01-900/71 BS	●					401	●		6000	4463-35	4.5
5483-814/01-6/01-900/71-910/04-917/35 BS	●	●		●		401	●		6000	4463-35	4.5
5483-814/01-748/26-6/01 BS						401			6000	4463-35	4.5
5483-814/01-748/26-6/01-900/71 BS	●					401	●		6000	4463-35	4.5
5483-H-814/01-6/01-900/71-910/04-911/35 BS	●	●		●		401	●		4800	5463-35	4.5
5483-H-814/01-6/10-900/71-910/04-911/35 BSN3.5	●	●		●		401	●		4800	5463-35	3.5
5483-H-814/01-748/26-6/01-900/71-910/24-911/35 BS	●		●	●		401	●		4800	5463-35	4.5
Two-needle versions											
5483-814/01-6/01 BS x 2.4						2x401	2.4		6000	4463-35	4.5
5483-814/06-94/01 BS x 6.0						406	6.0		5500	4463-35	4.5

Subclasses and work aids of the PFAFF 5483:

Subclasses:

Single-needle version:

-6/01

For plain seaming operations, standard part set shape.

-6/10

Bridge-type part set with tandem foot, special for seat seams

Two-needle version:

-6/01

For plain seaming operations, standard part set shape. Standard needle gauges: 2.4, 4.8, 6.4 and 10.0 mm

-94/01

For folding both sides of a tape downwards and top-stitching them, e.g. belt loops

Work aids:

-900/71 Thread trimmer

Electro-pneumatically controlled.

-910/04 Automatic foot lift

Electro-pneumatically controlled.

-910/24 Automatic foot lift in connection with puller -748/26

Electro-pneumatically controlled.

-911/35 Backtacking system

Electro-pneumatically controlled.

-917/35 Stitch condensation

Electro-pneumatically controlled.

-925/03 Air filter/regulator

PFAFF 5483-814/01-6/01-748/26

Single-needle version

High-speed seamer with puller feed, especially for long plies of the same shape. The puller works directly behind the presser foot. The puller width is 10 mm and its diameter 30 mm. The stroke is infinitely variable from the outside and the puller has two pre-selectable firm edge guides. The puller is raised by hand-lever or by automatic foot lift (-910/24).

PFAFF 5483-814/06-94/01

Two-needle version

Two-needle high-speed covering-stitch seamer for edge-stitching fabric edges and top-stitching, e.g. for making up belt loops.

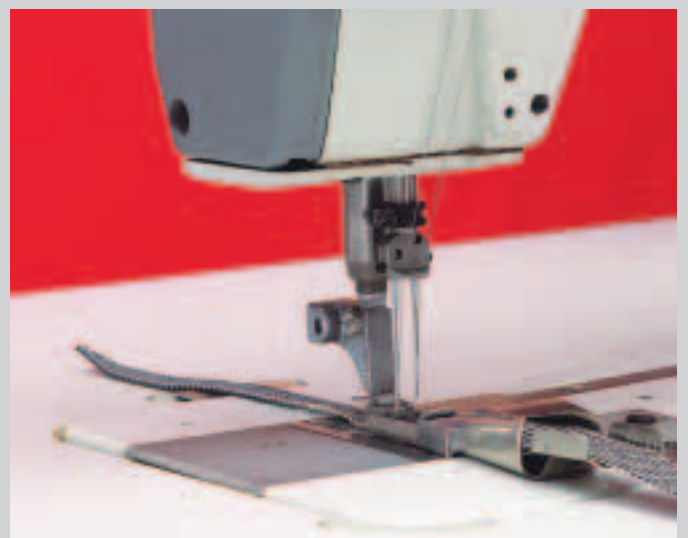
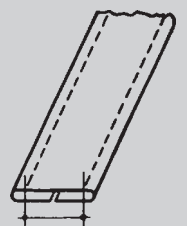

Technical data:

Stitch type:

see table

Max. sewing speed:

see table

Balance wheel:

65 mm eff. dia.

Motor power: 0.55 kW

Max. stitch length:

see table

Needle system:

see table

Fabric clearance:

7.0 mm or 9.0 mm at 5483-H

Clear work space:

260 x 130 mm

Bedplate dimensions:

476 x 177 mm

Net weight (head only):

approx. 37 kg

Gross weight (head in carton):

approx. 45 kg

Carton dimensions (head):

70 x 30 x 54 cm

This machine is equipped with finger-guard,
belt- and take-up lever guards as standard.

Hotlines:

Technical service : ++49-175/2243-101

Application consultancy : ++49-175/2243-102

Spare-parts hotline : ++49-175/2243-103



PFAFF Industrie Maschinen AG

- Postfach 3020
D-67653 Kaiserslautern
- Königstr. 154
D-67655 Kaiserslautern

Telefon: ++49-631/200-0

Telefax: ++49-631/17202

Internet: www.pfaff-industrial.com